

Multi-Contact

MC

STÄUBLI

Rapid connection system FSA10K/16BL

Utilitiesline | Industrial Connectors



FSA10K/16BL rapid connection system with replaceable contact claw

FSA10K/16BL

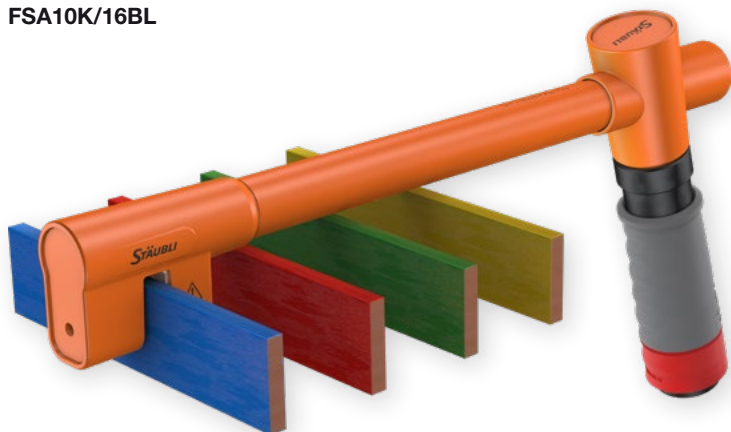

New Flat Bar clamp with plug connection 16BL specially designed for use on:

- Parallel busbars
- Bare, painted, or otherwise insulated busbars

Product features:

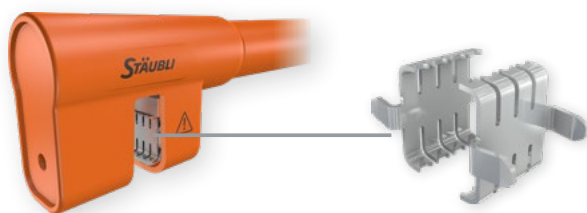

Patented replaceable contact claw



Extra narrow head and extra long design.

Termination with 16BL system.



360° rotation of handle.

Customer Benefits:

Service friendly and time saving

- Can break through insulated or painted busbars
- Easy to exchange worn/damaged contact elements

Maximum flexibility

- For connection over several busbars
- For easier access to busbar in hard to reach positions
- Suitable for use with free connectors from the new 16BL system

Easy handling:

- Enables optimal access to busbars
- Reduces forces at the contact area

Increased operator safety thanks to compatibility with 16BL system:

- Color coding
- 45° bayonet locking
- Safety latch when mated with 16BL socket

Quick and secure fastening to busbars

A torque limiter wrench tool is used to securely clamp and release the FSA10K to/from the busbars.

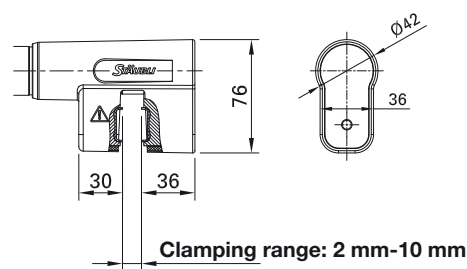
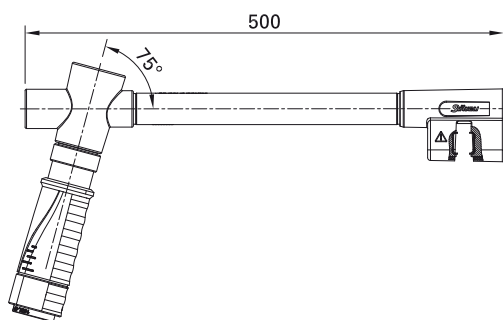

Technical data	
Rated current	530 A
Rated voltage	1000 V
Short-circuit current	12 kA, 1 s; 10 kA, 3 s; 9 kA, 4 s
Rated peak withstand current	30 kA
Rated impulse voltage	12 kV
Overvoltage category/Pollution degree	CAT III/3
Ambient temperature range	-40°C...+80°C
Clamping range	2 mm-10 mm
Thickness of busbar	5 mm ¹⁾ -10 mm
Required contact area on each side of the busbar	40 mm x 35 mm
Type of termination	Plug connection 16BL/Adapters available for 16BV system
Length	500 mm
For bare or insulated busbars	
Max. busbar insulation:	
– Painting thickness	0.15 mm
– Insulating tape	0.2 mm
– Heat-shrink tubing	1 mm
Operating cycles	>1'000, depending on conditions (replaceable contact claw)

Order No.	Type	Description	*Colors
12.1278-*	FSA10K/16BL-CP-SET	Rapid connection system with extra contact claw set	22 23 24 25 ²⁾
12.0501	FSA20-WZ	Torque wrench tool, 10 Nm	
12.1275	K-F-FSA10K CONTACT CLAW AG-SET	Contact claw set (1 pair)	
15.5882	16BL-CP/PC	Protective cover to protect the connectors from dust and water when unmated	
12.1279	FSA10K/16BL-TC	Transport case with trolley, empty, suited for 4 x FSA10K + 1 x FSA20-WZ	



Assembly instructions MA407

www.staubli.com/electrical

* Add the desired color code

¹⁾ The busbars need to be supported adequately to prevent twisting effects.

²⁾ Additional colors upon request



■ Stäubli Units ○ Agents

Global presence of the Stäubli Group

www.staubli.com